

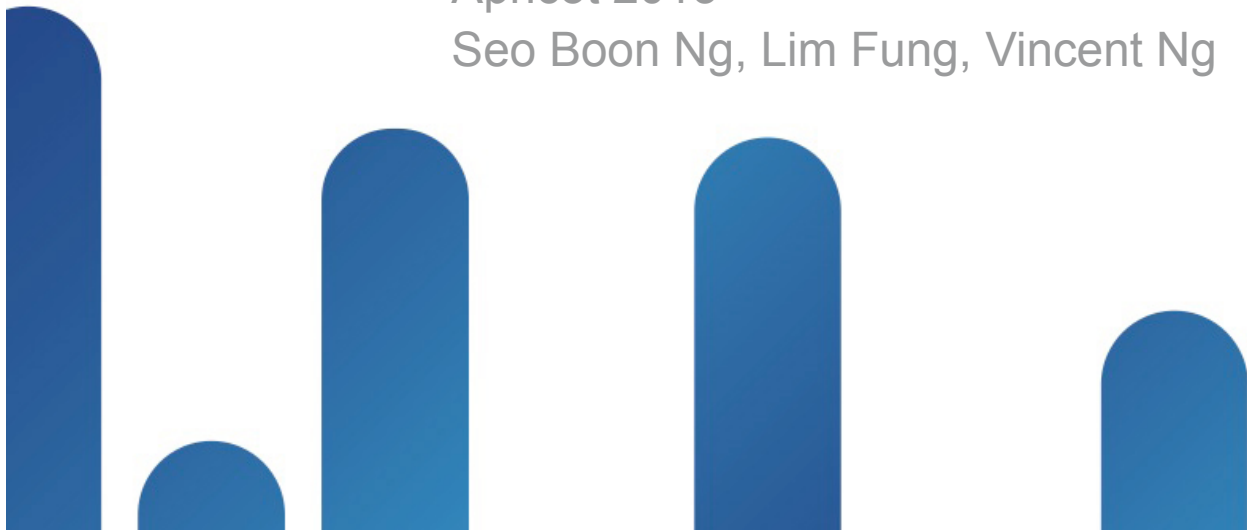

Introduction to MPLS

Apricot 2013

Seo Boon Ng, Lim Fung, Vincent Ng





Session Goals

Objectives

- Understand history and business drivers for MPLS
- Learn about MPLS customer and market segments
- Understand the problems MPLS is addressing
- Understand the major MPLS technology components
- Understand typical MPLS applications
- Understand benefits of deploying MPLS
- Learn about MPLS futures; where MPLS is going



Agenda

Topics

- Introduction
- MPLS Technology Basics
- MPLS Layer-3 VPNs
- MPLS Layer-2 VPNs
- Advanced Topics
- Summary

Introduction



What is MPLS?

Brief Summary

- It's all about labels ...
- Use the best of both worlds
 - Layer-2 (ATM/FR): efficient forwarding and traffic engineering
 - Layer-3 (IP): flexible and scalable
- MPLS forwarding plane
 - Use of labels for forwarding Layer-2/3 data traffic
 - Labeled packets are being switched instead of routed
 - Leverage layer-2 forwarding efficiency
- MPLS control/signaling plane
 - Use of existing IP control protocols extensions + new protocols to exchange label information
 - Leverage layer-3 control protocol flexibility and scalability

Technology Comparison

Key Characteristics of IP, Native Ethernet, and MPLS

	IP	Native Ethernet	MPLS
Forwarding	Destination address based Forwarding table learned from control plane TTL support	Destination address based Forwarding table learned from data plane No TTL support	Label based Forwarding table learned from control plane TTL support
Control Plane	Routing Protocols	Ethernet Loop avoidance and signaling protocols	Routing Protocols MPLS protocols
Packet Encapsulation	IP Header	802.3 Header	MPLS shim header
QoS	8 bit TOS field in IP header	3-bit 802.1p field in VLAN tag	3 bit TC field in label
OAM	IP ping, traceroute	E-OAM	MPLS OAM

Evolution of MPLS

Technology Evolution and Main Growth Areas

- Evolved from tag switching in 1996 to full IETF standard, covering over 130 RFCs
- Key application initially were Layer-3 VPNs, followed by Traffic Engineering (TE), and Layer-2 VPNs

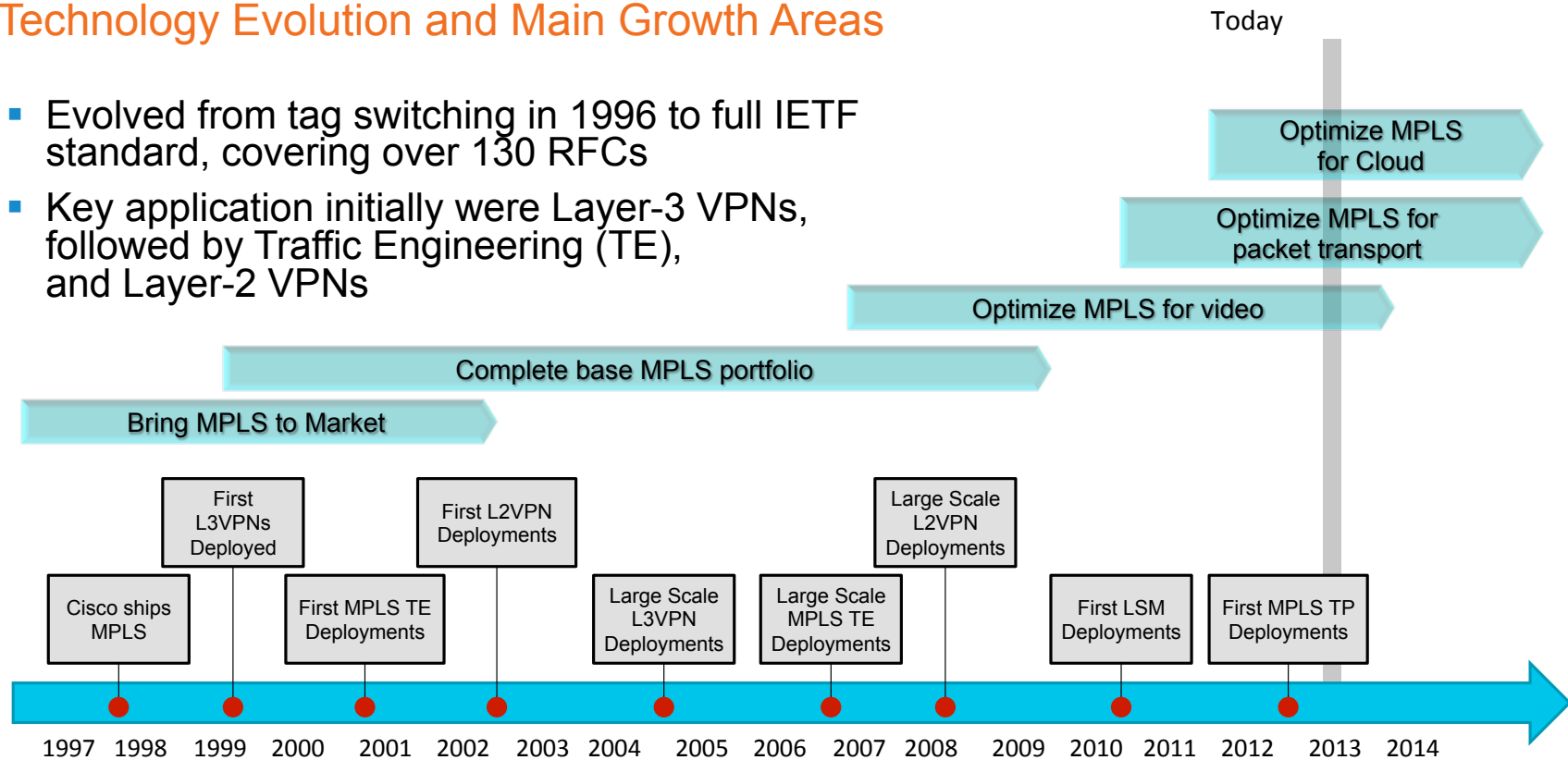

Market Segments

MPLS Business Drivers and Typical Deployment Characteristics

	Business Drivers	Business Goals	MPLS Capabilities
Service Provider	<ul style="list-style-type: none"> • Networking service reliability • Cost effective service bandwidth • Flexible enablement of existing and new services 	<ul style="list-style-type: none"> • Leverage single network for scalable delivery of multiple services • Optimize network capacity to meet current and future growth of service bandwidth • Deliver premium services with guaranteed SLAs 	Layer-3 VPN Layer-2 VPN MPLS TE MPLS OAM, QoS
Enterprise	<ul style="list-style-type: none"> • Mergers and acquisitions • Network consolidation • Shared services • Compliance 	<ul style="list-style-type: none"> • Network Segmentation • Network integration 	Layer-3 VPN
Data Center	<ul style="list-style-type: none"> • Multi-tenant hosting • Data Center Interconnect 	<ul style="list-style-type: none"> • Leverage single data center infrastructure for multiple users and services • Deliver geographic independent services from any data center 	Layer-2 VPN Layer-3 VPN

MPLS Technology Basics

Technology Building Blocks of MPLS

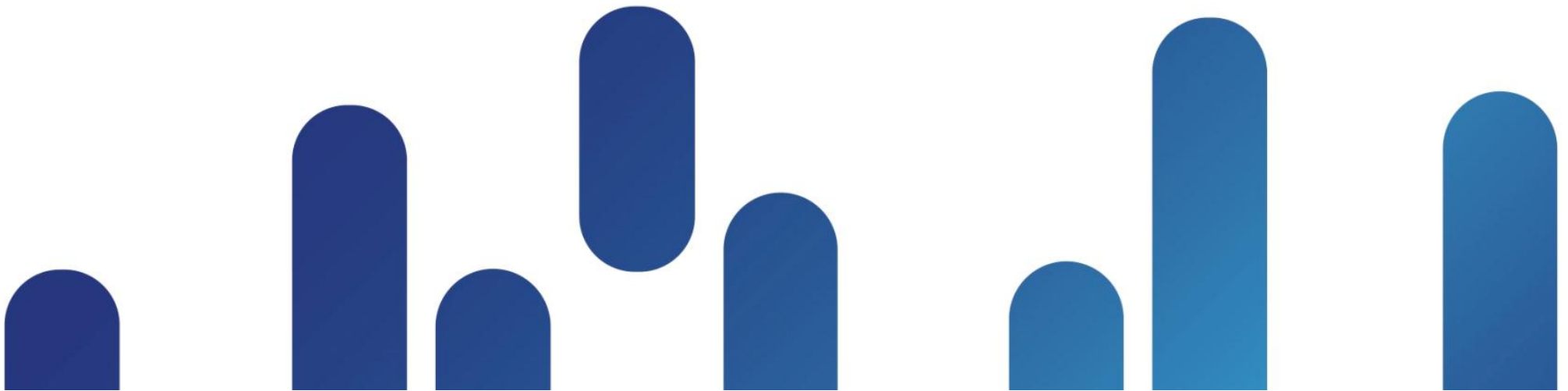

Topics

Basics of MPLS Signaling and Forwarding

- MPLS reference architecture
- MPLS Labels
- MPLS signaling and forwarding operations
- MPLS Traffic Engineering
- MPLS OAM and MIBs

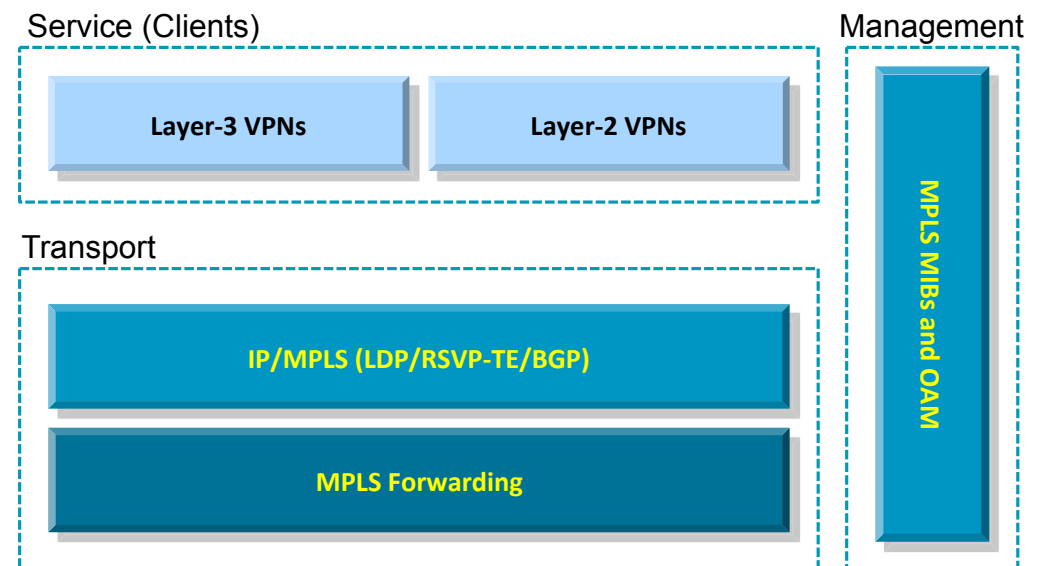

MPLS Reference Architecture

Different Type of Nodes in a MPLS Network

- P (Provider) router
 - Label switching router (LSR)
 - Switches MPLS-labeled packets
- PE (Provider Edge) router
 - Edge router (LER)
 - Imposes and removes MPLS labels
- CE (Customer Edge) router
 - Connects customer network to MPLS network

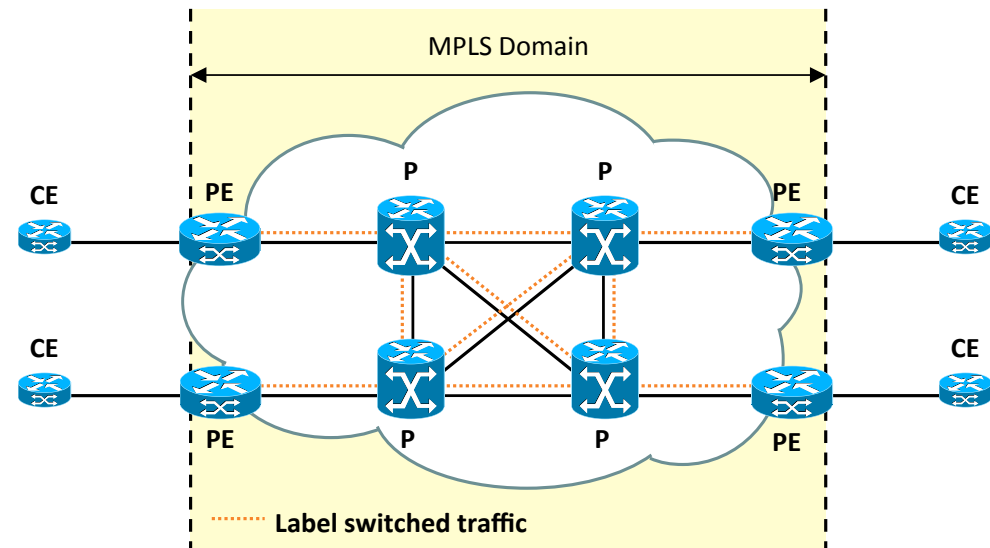

MPLS Shim Labels

Label Definition and Encapsulation

- Labels used for making forwarding decision
- Multiple labels can be used for MPLS packet encapsulation
 - Creation of a label stack
- Outer label always used for switching MPLS packets in network
- Remaining inner labels used to specific services (e.g., VPNs)

MPLS Label

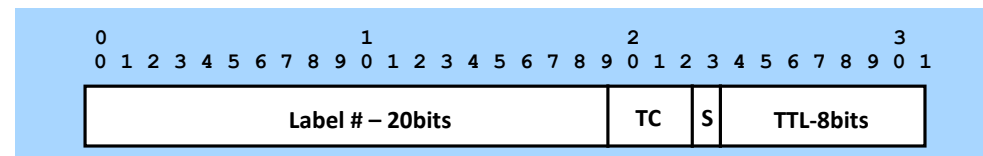

TC = Traffic Class: 3 Bits; S = Bottom of Stack; TTL = Time to Live

MPLS Label Encapsulation



MPLS Label Stack

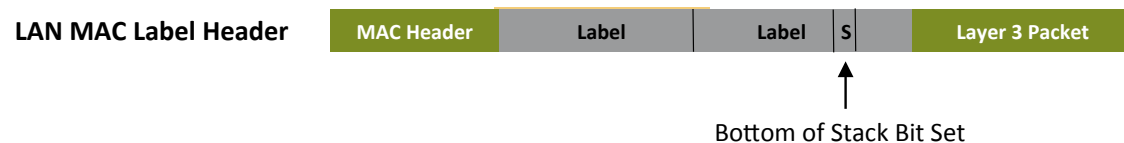

MPLS QoS

QoS Marking in MPLS Labels

- MPLS label contains 3 TC bits
- Used for packet classification and prioritization
 - Similar to Type of Service (ToS) field in IP packet (DSCP values)
- DSCP values of IP packet mapped into TC bits of MPLS label
 - At ingress PE router
- Most providers have defined 3–5 service classes (TC values)
- Different DSCP <-> TC mapping schemes possible
 - Uniform mode, pipe mode, and short pipe mode

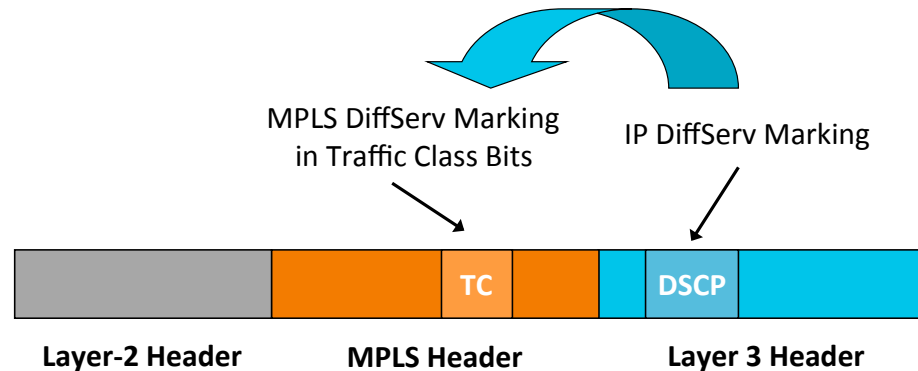

Basic MPLS Forwarding Operations

How Labels Are Being Used to Establish End-to-end Connectivity

- Label imposition (PUSH)
 - By ingress PE router; classify and label packets
 - Based on Forwarding Equivalence Class (FEC)
- Label swapping or switching
 - By P router; forward packets using labels; indicates service class & destination
- Label disposition (POP)
 - By egress PE router; remove label and forward original packet to destination CE

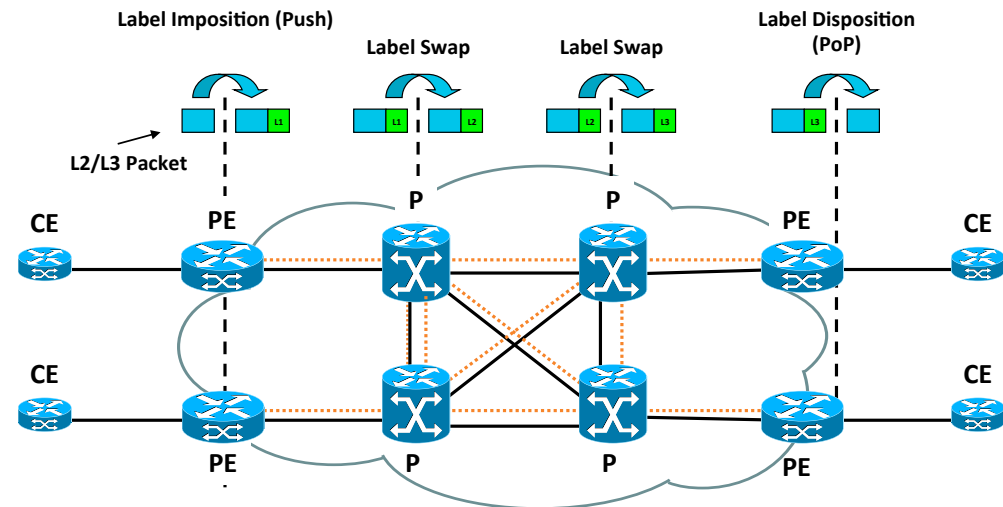

MPLS Path (LSP) Setup and Traffic Forwarding

MPLS Traffic Forwarding and MPLS Path (LSP) Setup

- LSP signaling
 - Either LDP* or RSVP
 - Leverages IP routing
 - Routing table (RIB)
- Exchange of labels
 - Label bindings
 - Downstream MPLS node advertises what label to use to send traffic to node
- MPLS forwarding
 - MPLS Forwarding table (FIB)

	IP	MPLS
Forwarding	Destination address based Forwarding table learned from control plane TTL support	Label based Forwarding table learned from control plane TTL support
Control Plane	OSPF, IS-IS, BGP	OSPF, IS-IS, BGP LDP, RSVP
Packet Encapsulation	IP Header	One or more labels
QoS	8 bit TOS field in IP header	3 bit TC field in label
OAM	IP ping, traceroute	MPLS OAM

* LDP signaling assumed for next the examples

MPLS Path (LSP) Setup

Signaling Options

- LDP signaling
 - Leverages existing routing
- RSVP signaling
 - Aka MPLS RSVP/TE
 - Enables enhanced capabilities, such as Fast ReRoute (FRR)

	LDP	RSVP
Forwarding path	LSP	LSP or TE Tunnel Primary and, optionally, backup
Forwarding Calculation	Based on IP routing database Shortest-Path based	Based on TE topology database Shortest-path and/or other constraints (CSPF calculation)
Packet Encapsulation	Single label	One or two labels
Signaling	By each node independently Uses existing routing protocols/information	Initiated by head-end node towards tail-end node Uses routing protocol extensions/information Supports bandwidth reservation Supports link/node protection

IP Packet Forwarding Example

Basic IP Packet Forwarding

- IP routing information exchanged between nodes
 - Via IGP (e.g., OSPF, IS-IS)
- Packets being forwarded based on destination IP address
 - Lookup in routing table (RIB)

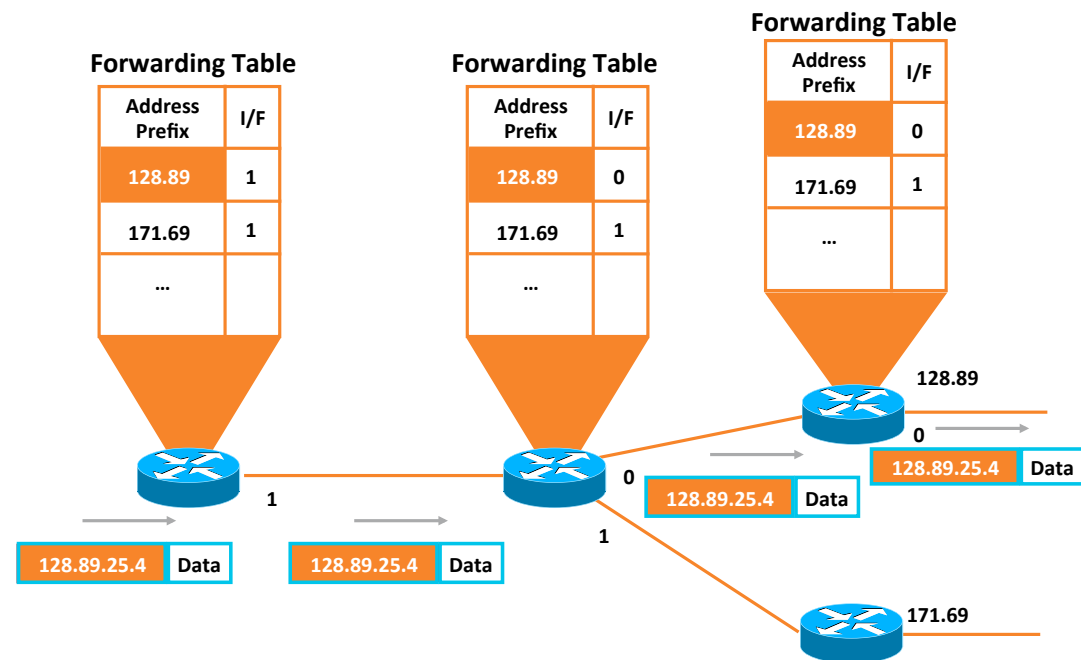

MPLS Path (LSP) Setup

Step 1: IP Routing (IGP) Convergence

- Exchange of IP routes
 - OSPF, IS-IS, EIGRP, etc.
- Establish IP reachability

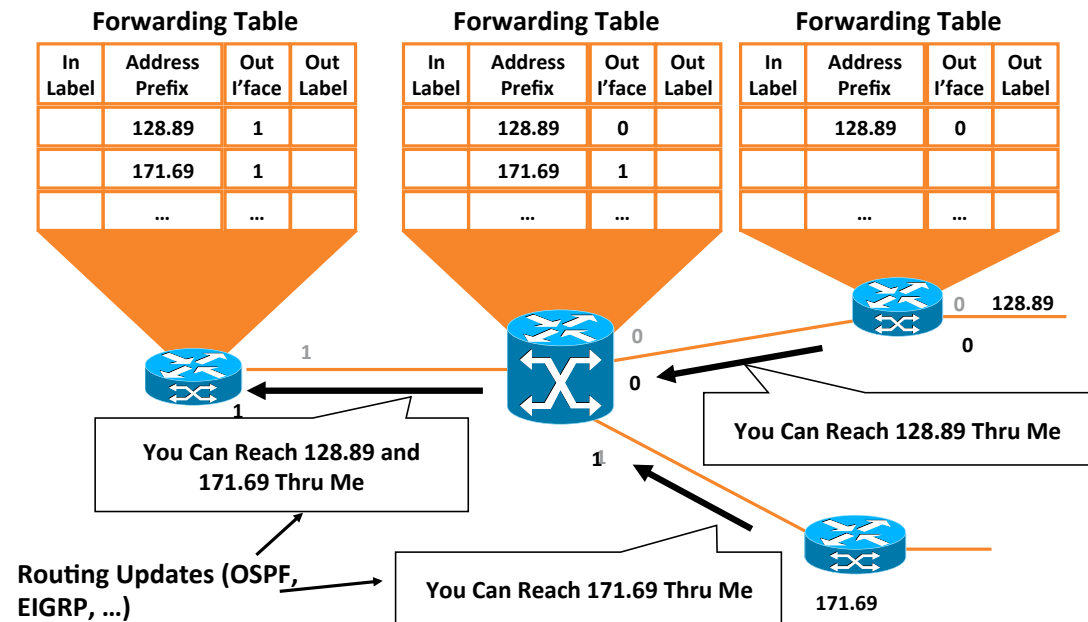

MPLS Path (LSP) Setup

Step 2A: Assignment of Local Labels

- Each MPLS node assigns a local label to each route in local routing table
 - In label

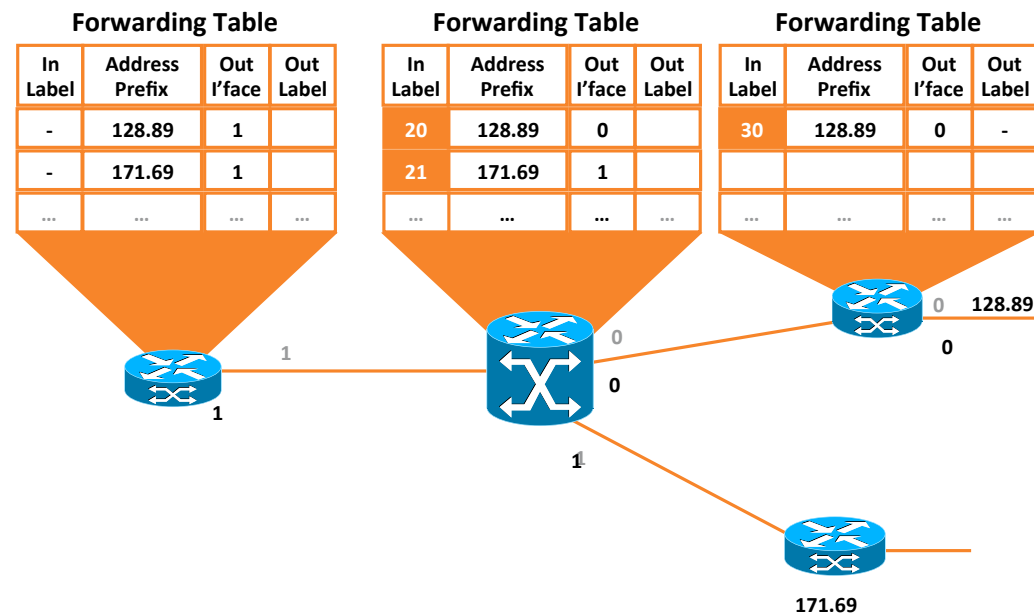

MPLS Path (LSP) Setup

Step 2B: Assignment of Remote Labels

- Local label mapping are sent to connected nodes
- Receiving nodes update forwarding table
 - Out label

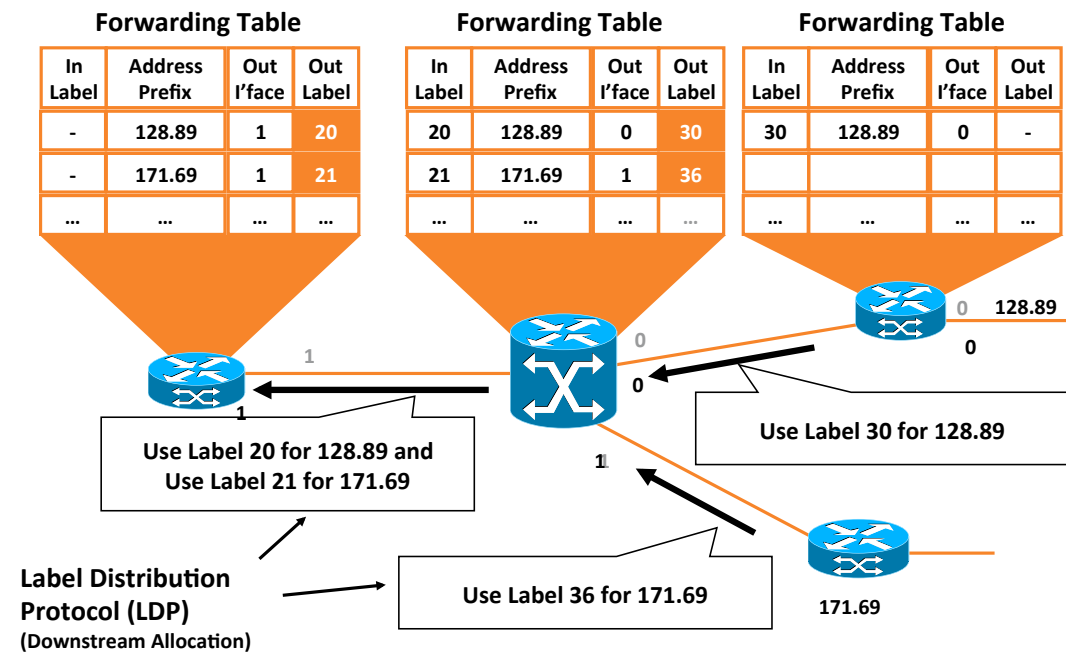

MPLS Traffic Forwarding

Hop-by-hop Traffic Forwarding Using Labels

- Ingress PE node adds label to packet (push)
 - Via forwarding table
- Downstream node use label for forwarding decision (swap)
 - Outgoing interface
 - Out label
- Egress PE removes label and forwards original packet (pop)

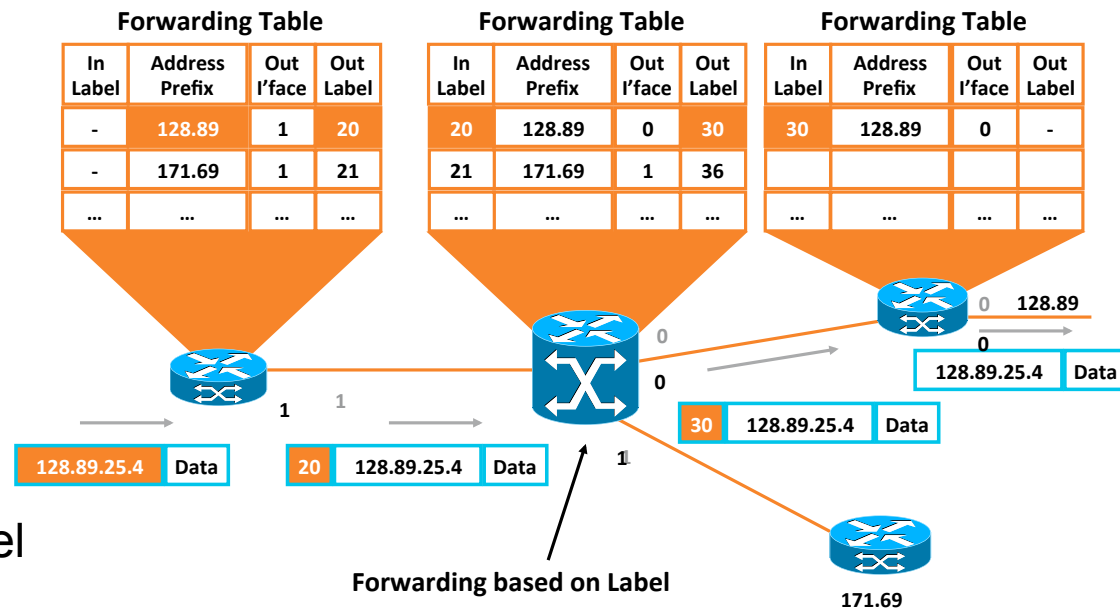

MPLS SNMP MIBs

SNMP Management Access to MPLS Resources

- **MPLS-LSR-STD-MIB**
 - Provides LSP end-point and LSP cross-connect information
 - Frequently used: none ☹
- **MPLS-LDP-STD-MIB**
 - Provides LDP session configuration and status information
 - Frequently used: LDP session status Trap notifications
- **MPLS-L3VPN-STD-MIB**
 - Provides VRF configuration and status information and associated interface mappings
 - Frequently used: VRF max-route Trap notifications
- **MPLS-TE-STD-MIB**
 - Provides TE tunnel configuration and status information
 - Frequently used: TE Tunnel status Trap notifications

MPLS OAM

Tools for Reactive and Proactive Trouble Shooting of MPLS Connectivity

- **MPLS LSP Ping**
 - Used for testing end-to-end MPLS connectivity similar to IP ping
 - Can be used to validate reachability of LDP-signaled LSPs, TE tunnels, and PWs
- **MPLS LSP Trace**
 - Used for testing hop-by-hop tracing of MPLS path similar to traceroute
 - Can be used for path tracing LDP-signaled LSPs and TE tunnels
- **MPLS LSP Multipath (ECMP) Tree Trace**
 - Used to discover all available equal cost LSP paths between PEs
 - Unique capability for MPLS OAM; no IP equivalent!
- **Auto IP SLA**
 - Automated discovery of all available equal cost LSP paths between PEs
 - LSP pings are being sent over each discovered LSP path

Why MPLS QoS



The Need for Differentiated Services

- Typically different traffic types (packets) sent over MPLS networks
 - E.g., Web HTTP, VoIP, FTP, etc.
- Not all traffic types/flows have the same performance requirements ...
 - Some require low latency to work correctly; e.g., video
- MPLS QoS used for traffic prioritization to guarantee minimal traffic loss and delay for high priority traffic
 - Involves packet classification and queuing
- MPLS leverages mostly existing IP QoS architecture
 - Based on Differentiated Services (DiffServ) model; defines per-hop behavior based on IP Type of Service (ToS) field

MPLS Uniform Mode

QoS Field Assignments in MPLS Network



- End-to-end behavior:
 - Original IP DSCP value not preserved
- At ingress PE:
 - IP DSCP value copied in EXP value of MPLS label
- EXP value changed in the MPLS core
 - Based on traffic load and congestion
- At egress PE:
 - EXP value copied back into IP DSCP value

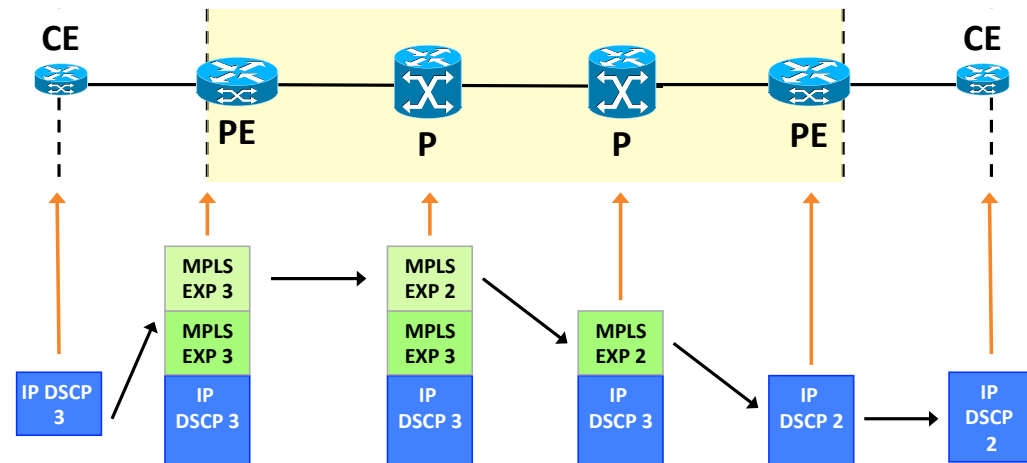

MPLS Pipe Mode

QoS Field Assignments in MPLS Network



- End-to-end behavior:
 - Original IP DSCP is preserved
- At ingress PE:
 - EXP value set based on ingress classification
- EXP changed in the MPLS core
 - Based on traffic load and congestion
- At egress PE:
 - EXP value not copied back into IP DSCP value

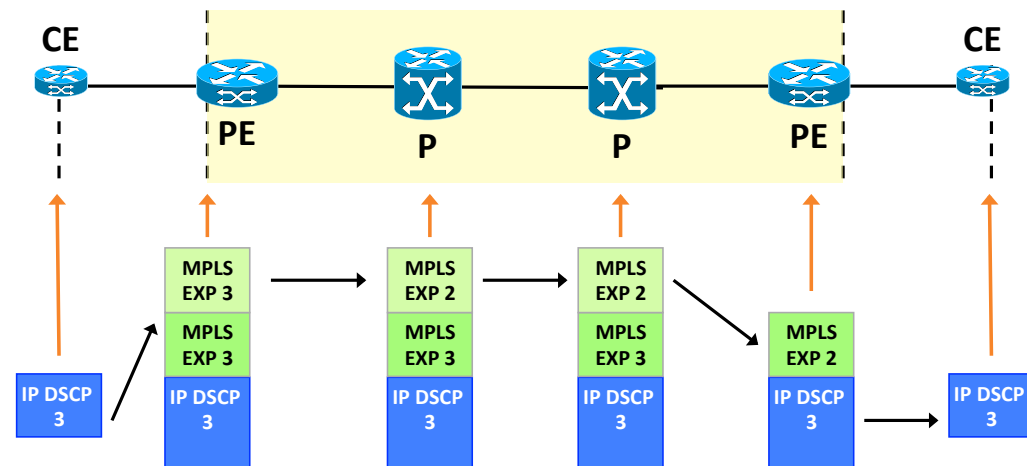

MPLS Short Pipe Mode

QoS Field Assignments in MPLS Network



- End-to-end behavior:
 - Original IP DSCP is preserved
- At ingress PE:
 - EXP value set based on ingress classification
- EXP changed in the MPLS core
 - Based on traffic load and congestion
- At egress PE:
 - Original IP DSCP value used for QoS processing

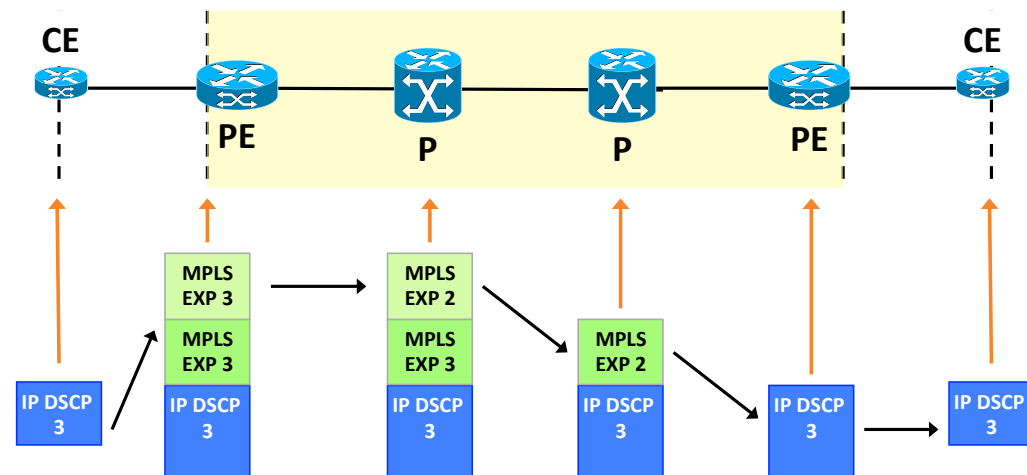

Summary

Key Takeaways

- MPLS networks consist of PE routers at in/egress and P routers in core
- Traffic is encapsulated with label(s) at ingress (PE router)
- Labels are removed at egress (PE router)
- MPLS forwarding operations include label imposition (PUSH), swapping, and disposition (POP)
- LDP and RSVP can be used for signaling label mapping information to set up an end-to-end Label Switched Path (LSP)
- RSVP label signaling enables setup of TE tunnels, supporting enhanced traffic engineering capabilities; traffic protection and path management
- MPLS OAM and MIBs can be used for MPLS connectivity validation and troubleshooting

MPLS Virtual Private Networks

Technology Overview

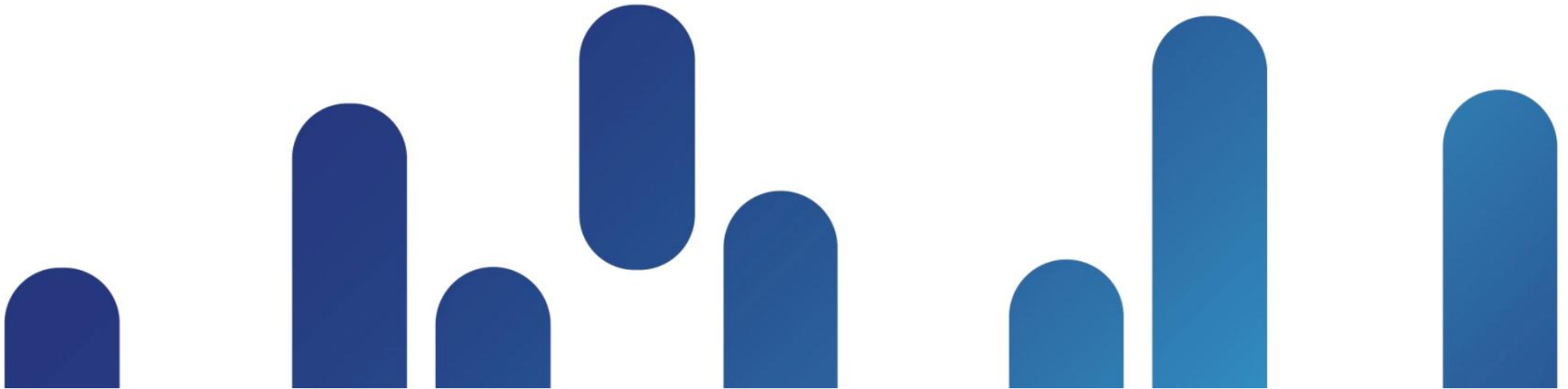

MPLS Virtual Private Networks

Topics

- Definition of MPLS VPN service
- Basic MPLS VPN deployment scenario
- Technology options

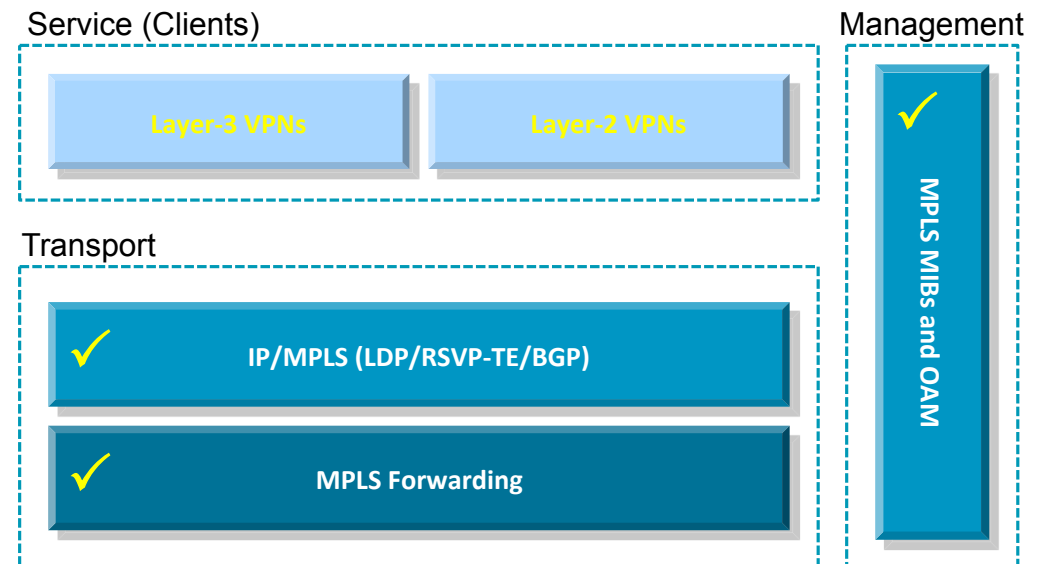

What Is a Virtual Private Network?

Definition

- Set of sites which communicate with each other in a secure way
 - Typically over a shared public or private network infrastructure
- Defined by a set of administrative policies
 - Policies established by VPN customers themselves (DIY)
 - Policies implemented by VPN service provider (managed/unmanaged)
- Different inter-site connectivity schemes possible
 - Full mesh, partial mesh, hub-and-spoke, etc.
- VPN sites may be either within the same or in different organizations
 - VPN can be either intranet (same org) or extranet (multiple orgs)
- VPNs may overlap; site may be in more than one VPN

MPLS VPN Example

Basic Building Blocks

- VPN policies
 - Configured on PE routers (manual operation)
- VPN signaling
 - Between PEs
 - Exchange of VPN policies
- VPN traffic forwarding
 - Additional VPN-related MPLS label encapsulation
- PE-CE link
 - Connects customer network to MPLS network; either layer-2 or layer-3

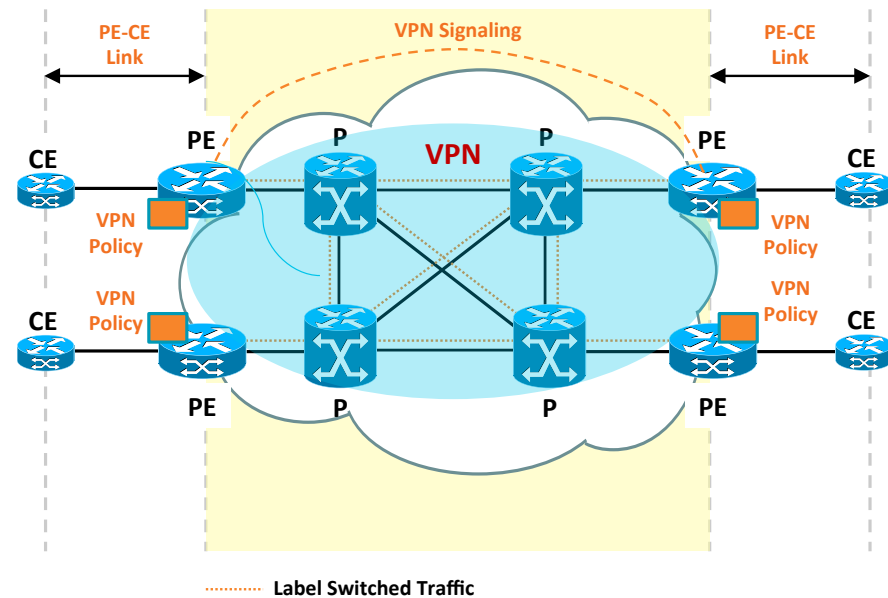

MPLS VPN Models

Technology Options

- **MPLS Layer-3 VPNs**
 - Peering relationship between CE and PE
- **MPLS Layer-2 VPNs**
 - Interconnect of layer-2 Attachment Circuits (ACs)

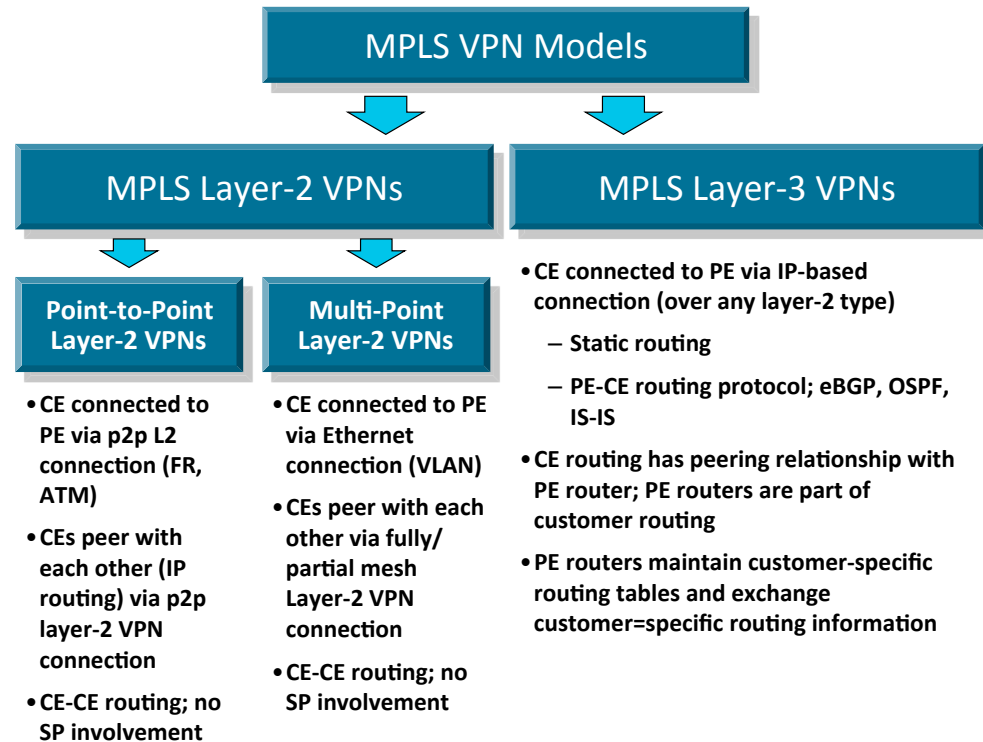

MPLS Layer-3 Virtual Private Networks

End-to-end Layer-3 Services Over MPLS Networks

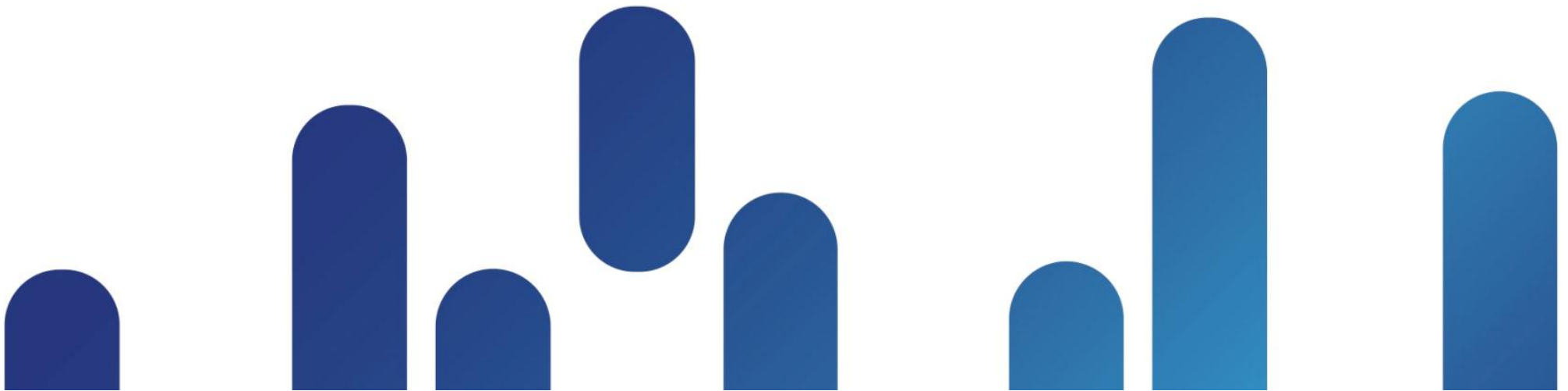

MPLS Layer-3 Virtual Private Networks

Topics

- Technology components
- VPN control plane mechanisms
- VPN forwarding plane
- Deployment use cases
 - Business VPN services
 - Network segmentation
 - Data Center access

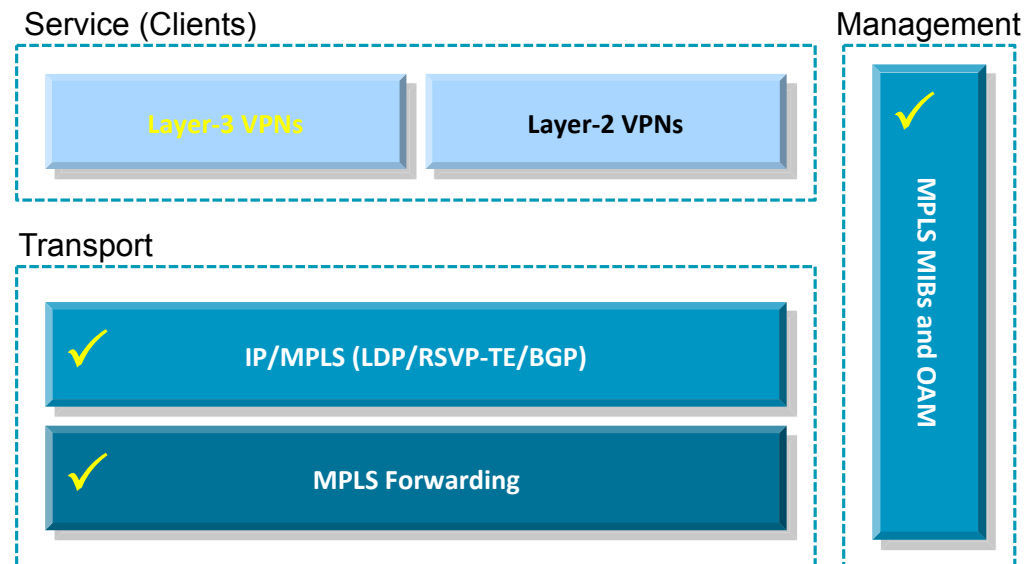

MPLS Layer-3 VPN Overview

Technology Components

- VPN policies
 - Separation of customer routing via virtual VPN routing table (VRF)
 - In PE router, customer interfaces are connected to VRFs
- VPN signaling
 - Between PE routers: customer routes exchanged via BGP (MP-iBGP)
- VPN traffic forwarding
 - Separation of customer VPN traffic via additional VPN label
 - VPN label used by receiving PE to identify VPN routing table
- PE-CE link
 - Can be any type of layer-2 connection (e.g., FR, Ethernet)
 - CE configured to route IP traffic to/from adjacent PE router
 - Variety of routing options; static routes, eBGP, OSPF, IS-IS

Virtual Routing and Forwarding Instance

Virtual Routing Table and Forwarding to Separate Customer Traffic

- Virtual routing and forwarding table
 - On PE router
 - Separate instance of routing (RIB) and forwarding table
- Typically, VRF created for each customer VPN
 - Separates customer traffic
- VRF associated with one or more customer interfaces
- VRF has its own routing instance for PE-CE configured routing protocols
 - E.g., eBGP

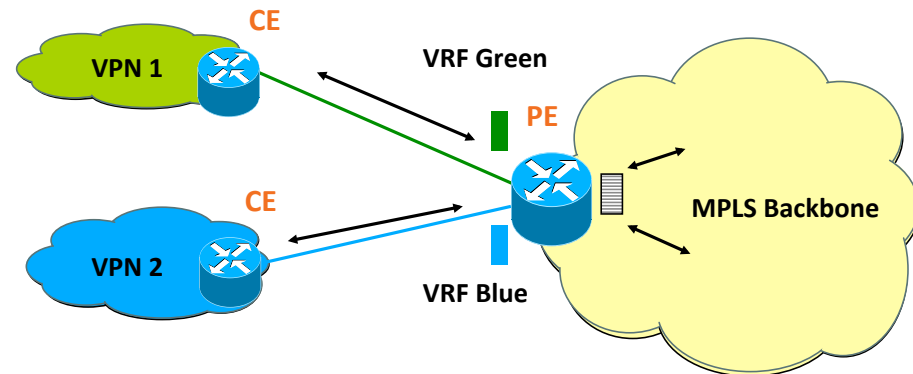

VPN Route Distribution

Exchange of VPN Policies Among PE Routers

- Full mesh of BGP sessions among all PE routers
 - BGP Route Reflector
- Multi-Protocol BGP extensions (MP-iBGP) to carry VPN policies
- PE-CE routing options
 - Static routes
 - eBGP
 - OSPF
 - IS-IS

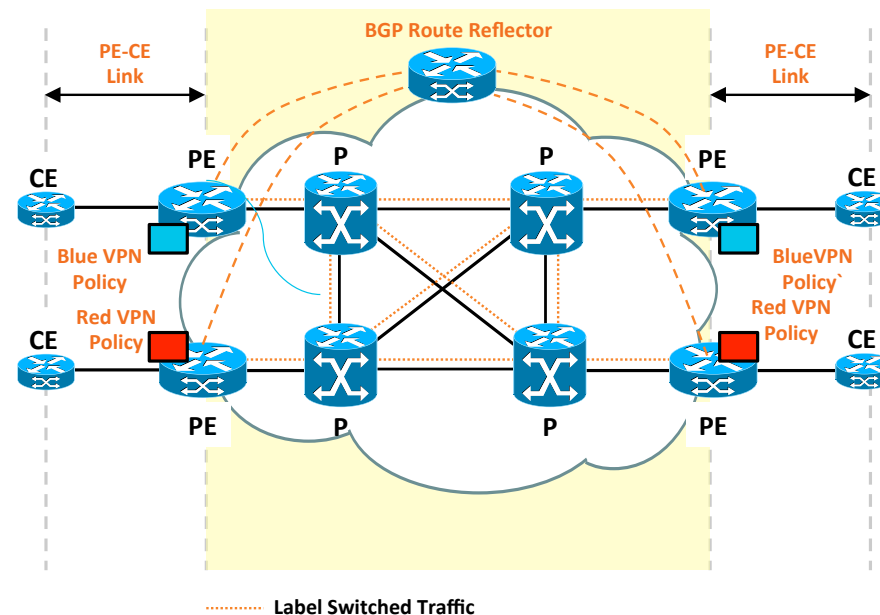

VPN Control Plane Processing

VRF Parameters

Make customer routes unique:

- **Route Distinguisher (RD):** 8-byte field, VRF parameters; unique value to make VPN IP routes unique
- **VPNv4 address:** RD + VPN IP prefix

Selective distribute VPN routes:

- **Route Target (RT):** 8-byte field, VRF parameter, unique value to define the import/export rules for VPNv4 routes
- **MP-iBGP:** advertises VPNv4 prefixes + labels

VPN Control Plane Processing

Interactions Between VRF and BGP VPN Signaling

1. CE1 redistribute IPv4 route to PE1 via eBGP
2. PE1 allocates VPN label for prefix learnt from CE1 to create unique VPNv4 route
3. PE1 redistributes VPNv4 route into MP-iBGP, it sets itself as a next hop and relays VPN site routes to PE2
4. PE2 receives VPNv4 route and, via processing in local VRF (green), it redistributes original IPv4 route to CE2

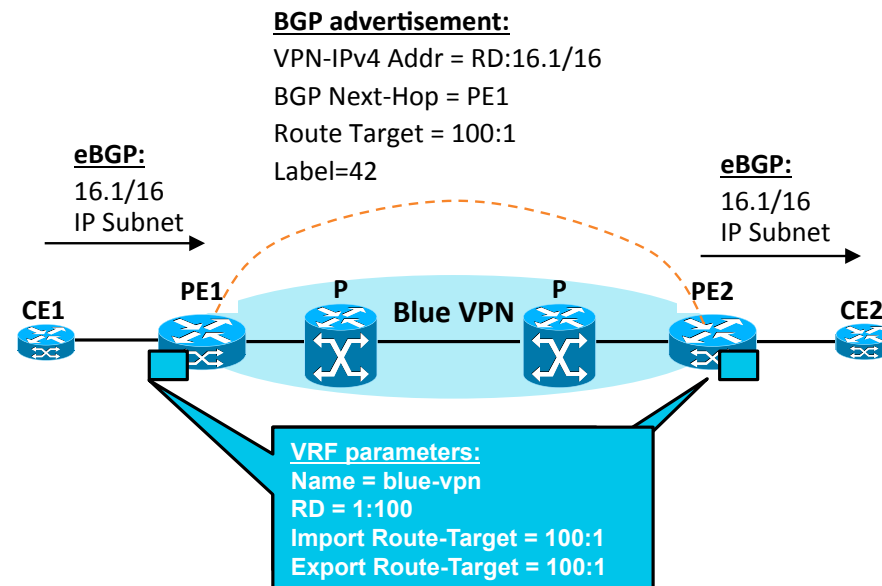

VPN Forwarding Plane Processing

Forwarding of Layer-3 MPLS VPN Packets

1. CE2 forwards IPv4 packet to PE2
2. PE2 imposes pre-allocated VPN label to IPv4 packet received from CE2
 - Learned via MP-IBGP
3. PE2 imposes outer IGP label A (learned via LDP) and forwards labeled packet to next-hop P-router P2
4. P-routers P1 and P2 swap outer IGP label and forward label packet to PE1
 - A->B (P2) and B->C (P1)
5. Router PE1 strips VPN label and IGP labels and forwards IPv4 packet to CE1

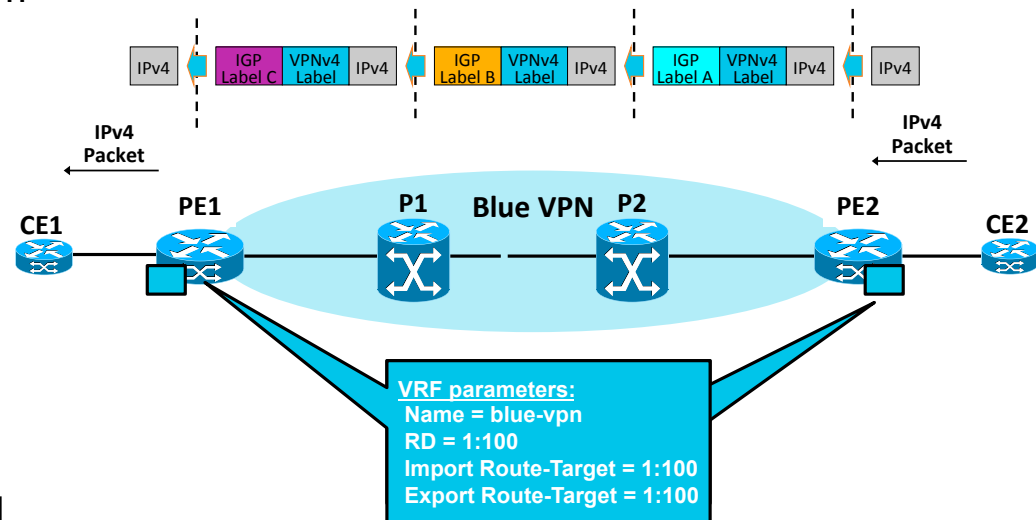

Service Provider Deployment Scenario

MPLS Layer-3 VPNs for Offering Layer-3 Business VPN Services

- **Deployment Use Case**
 - Delivery of IP VPN services to business customers
- **Benefits**
 - Leverage same network for multiple services and customers (CAPEX)
Highly scalable
 - Service enablement only requires edge node configuration (OPEX)
 - Different IP connectivity can be easily configured; e.g., full/partial mesh

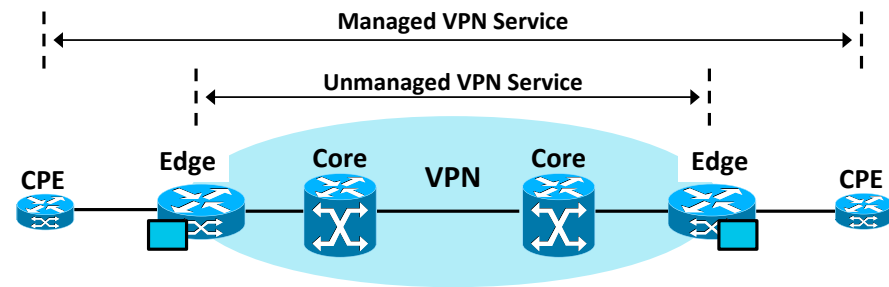

Network Segment	CPE	Edge	Core
MPLS Node	CE	PE	P
Typical Platforms	ASR1K ISR/G2	ASR9K 7600 ASR1K ASR903 ME3800X	CRS-1 GSR ASR9K

Enterprise Deployment Scenario

MPLS Layer-3 VPNs for Implementing Network Segmentation

- Deployment Use Case
 - Segmentation of enterprise network to provide selective connectivity for specific user groups and organizations
- Benefits
 - Network segmentation only requires edge node configuration
 - Flexible routing; different IP connectivity can be easily configured; e.g., full/partial mesh

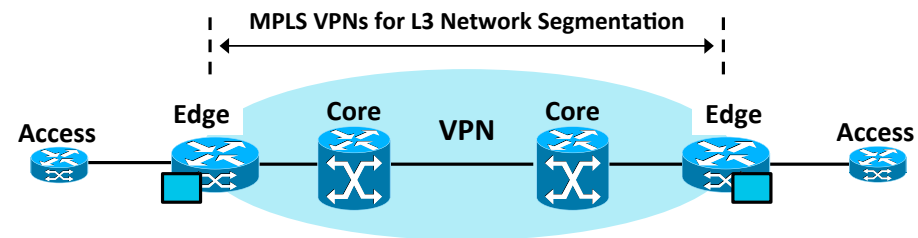

Network Segment	Access	Edge	Core
MPLS Node	CE	PE	P
Typical Platforms	ASR1K ISR/G2	7600 ASR1K	CRS-1 GSR ASR9K 7600 6500

Data Center Deployment Scenario

MPLS Layer-3 VPNs for Segmented L3 Data Center Access and Interconnect

- Deployment Use Case
 - Segmented WAN Layer-3 at Data Center edge
 - Layer-3 segmentation in Data Center
- Benefits
 - Only single Data Center edge node needed for segmented layer-3 access
 - Enables VLAN/Layer-2 scale (> 4K)

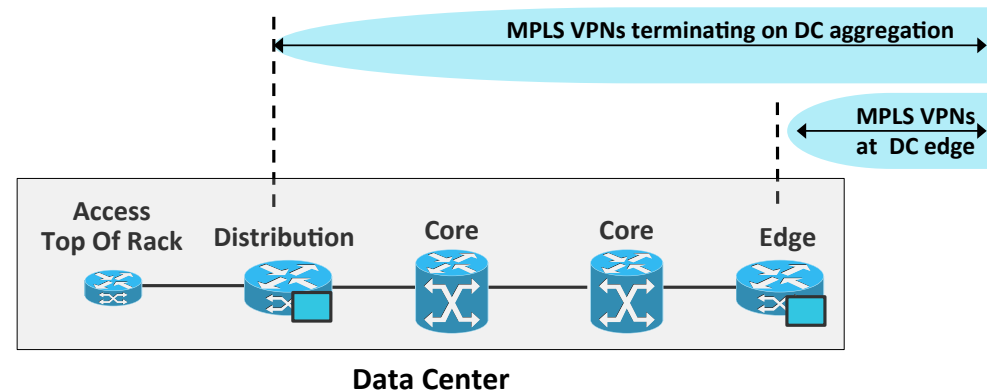

Network Segment	Distribution	Core	Edge
MPLS Node	CE or PE	P or CE	PE
Typical Platforms	N7K 6500	N7K 6500	ASR9K 7600

Summary

Key Takeaways

- MPLS Layer-3 VPNs provide IP connectivity among CE sites
 - MPLS VPNs enable full-mesh, hub-and-spoke, and hybrid IP connectivity
- CE sites connect to the MPLS network via IP peering across PE-CE links
- MPLS Layer-3 VPNs are implemented via VRFs on PE edge nodes
 - VRFs providing customer routing and forwarding segmentation
- BGP used for signaling customer VPN (VPNv4) routes between PE nodes
- To ensure traffic separation, customer traffic is encapsulated in an additional VPN label when forwarded in MPLS network
- Key applications are layer-3 business VPN services, enterprise network segmentation, and segmented layer-3 Data Center access

MPLS Layer-2 Virtual Private Networks

End-to-end Layer-2 Services Over MPLS Networks

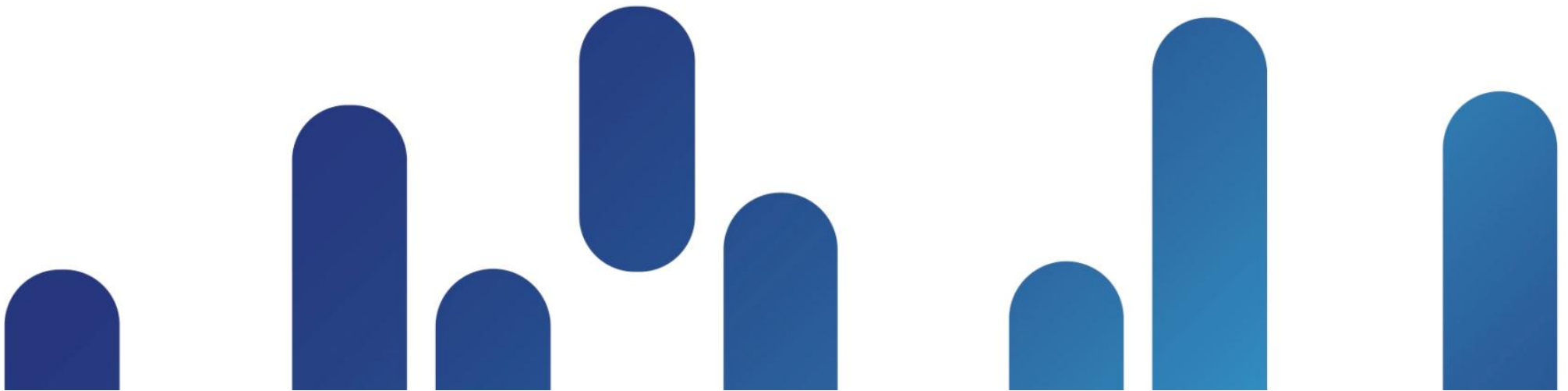

MPLS Layer-2 Virtual Private Networks

Topics

- L2VPN technology options
- P2P VPWS services (PWs)
 - Overview & Technology Basics
 - VPN control plane
 - VPN forwarding plane
- MP2MP VPLS services
 - Overview & Technology Basics
 - VPN control plane
 - VPN forwarding plane
- Deployment use cases
 - L2 Business VPN services
 - Data Center Interconnect

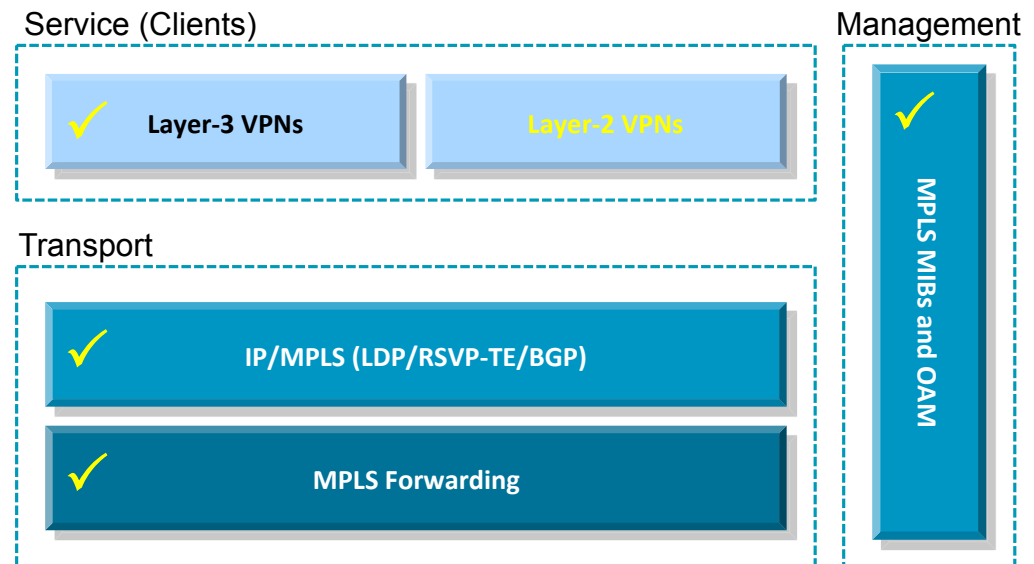

MPLS Layer-2 Virtual Private Networks

Technology Options

- VPWS services
 - Point-to-point
 - Referred to as Pseudowires (PWs)*
- VPLS services
 - Multipoint-to-Multipoint

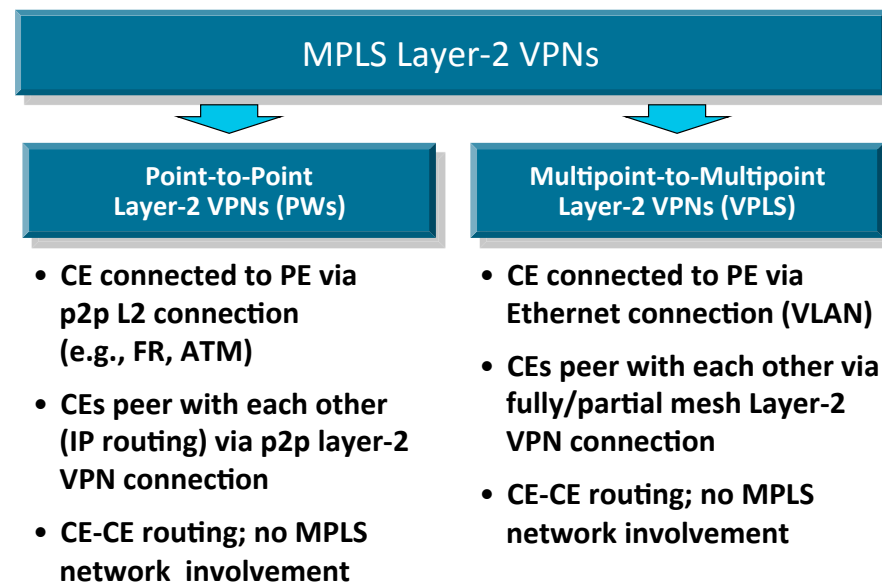

* Used to be referred to as Any Transport over MPLS or AToM as well.

Virtual Private Wire Services (VPWS)

Overview of Pseudowire (PW) Architecture

- Based on IETF's Pseudo-Wire (PW) Reference Model
- Enables transport of any Layer-2 traffic over MPLS
- Includes additional VC label encapsulation and translation of L2 packets
 - ATM, ATM, FR, or PPP
- PE-CE link is referred to as Attachment Circuit (AC)
- Support for L2 interworking
- PWs are bi-directional

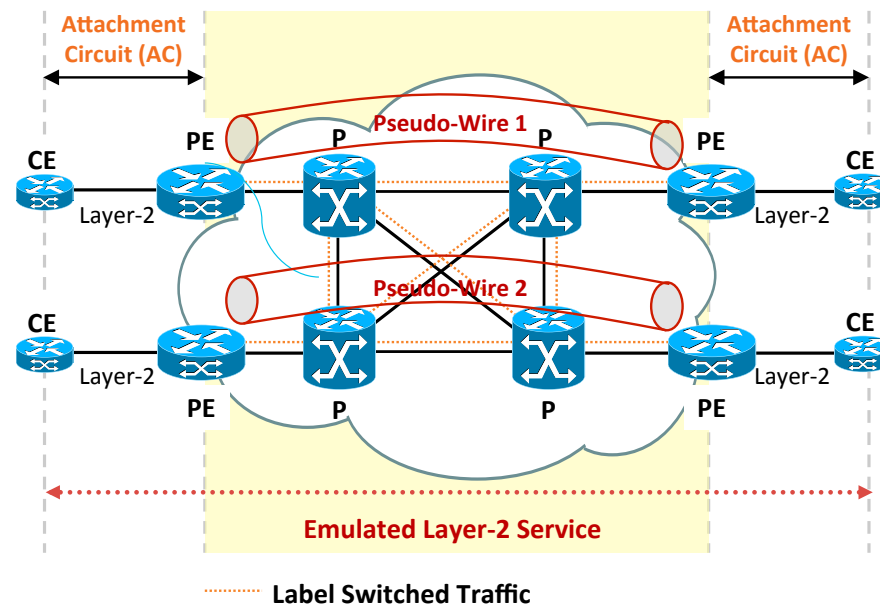

Virtual Private Wire Services (VPWS)

Technology Components

- VPN policies
 - Virtual cross-connect (Xconnect)
 - Maps customer interface (AC) to PW (1:1 mapping)
- VPN signaling
 - Targeted LDP* or BGP session between ingress and egress PE router
 - Virtual Connection (VC)-label negotiation, withdrawal, error notification
- VPN traffic forwarding
 - 1 or 2 labels used for encapsulation + 1 (IGP) label for forwarding: VC label + optional control word
 - Inner de-multiplexer (VC) label: identifies L2 circuit (packet)
 - Control word: replaces layer-2 header at ingress; used to rebuild layer-2 header at egress
 - Outer tunnel (IGP) label: to get from ingress to egress PE using MPLS LSP
- PE-CE link
 - Referred to as Attachment Circuit (AC)
 - Can be any type of layer-2 connection (e.g., FR, ATM)

* LDP is assumed as signaling protocol for next examples

VPWS Control Plane Processing

Signaling of a New Pseudo-Wire

1. New Virtual Circuit (VC) cross-connect connects customer L2 interface (AC) to new PW via VC ID and remote PE ID
2. New targeted LDP session between PE1 and PE2 is established, in case one does not already exist
3. PE binds VC label with customer layer-2 interface and sends label-mapping to remote PE
4. Remote PE receives LDP label binding message and matches VC ID with local configured VC cross-connect

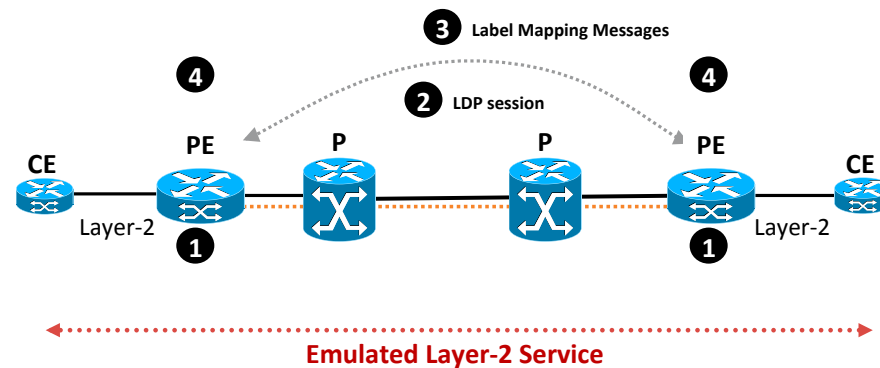

VPWS Forwarding Plane Processing

Forwarding of Layer-2 Traffic Over PWs

1. CE2 forwards L2 packet to PE2.
2. PE2 pushes VC (inner) label to L2 packet received from CE2
 - Optionally, a control word is added as well (not shown)
3. PE2 pushed outer (Tunnel) label and forwards packet to P2
4. P2 and P1 forward packet using outer (tunnel) label (swap)
5. Router PE2 pops Tunnel label and, based on VC label, L2 packet is forwarded to customer interface to CE1, after VC label is removed
 - In case control word is used, new layer-2 header is generated first

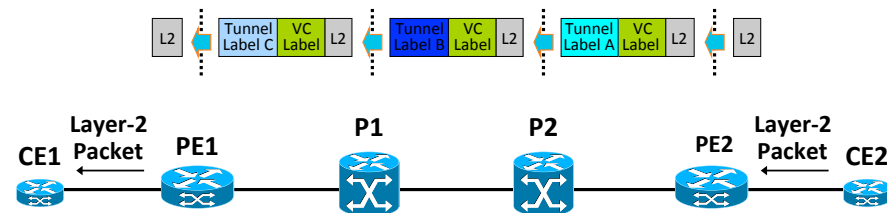

Virtual Private LAN Services

Overview of VPLS Architecture

- Architecture for Ethernet Multipoint Services over MPLS
- VPLS network acts like a virtual switch that emulates conventional L2 bridge
- Fully meshed or Hub-Spoke topologies supported
- PE-CE link is referred to as Attachment Circuit (AC)
 - Always Ethernet

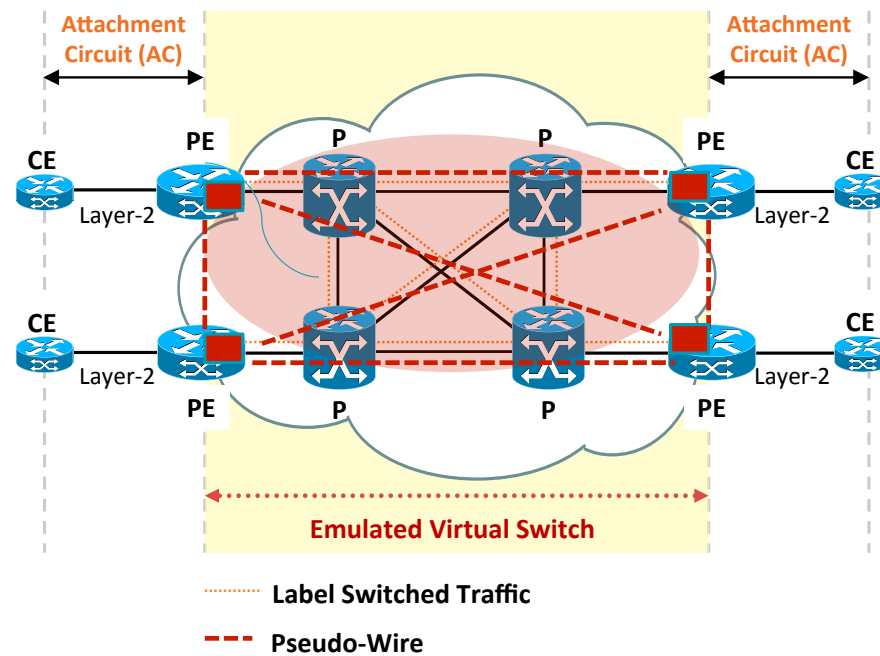

Virtual Private LAN Services (VPLS)

Technology Components

- VPN policies
 - Virtual Switching Instance or VSI
 - One or more customer interfaces are connected to VSI
 - One or more PWs for interconnection with related VSI instances on remote PE
- VPN signaling
 - Full mesh of targeted LDP* (VC exchange) and/or BGP sessions (discovery and VC exchange)
 - Virtual Connection (VC)-label negotiation, withdrawal, error notification
- VPN traffic forwarding
 - 1 VC label used for encapsulation + 1 (IGP) label for forwarding
 - Inner de-multiplexer (VC) label: identifies VSI
 - Outer tunnel (IGP) label: to get from ingress to egress PE using MPLS LSP
- PE-CE link
 - Referred to as Attachment Circuit (AC)
 - Ethernet VCs are either port mode or VLAN ID

* LDP is assumed as signaling protocol for next examples

VPLS Forwarding Plane Processing

Forwarding of Layer-2 Traffic Over VPLS Network

MAC learning:

- For new L2 packets
- VSI forwarding table updated
- Packets flooded to all PEs over PWs

Layer-2 Packet Forwarding:

- For L2 packets with known destination MAC addresses
- Lookup in VSI forwarding table
- L2 packet forwarded onto PWs to remote PE/VSI

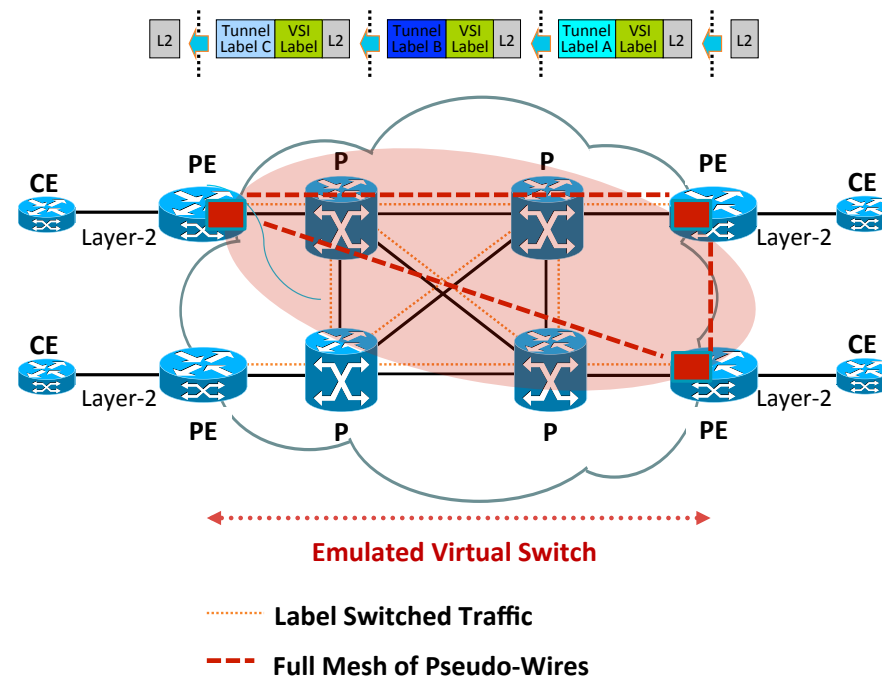

Service Provider Deployment Scenario

PWs for Offering Layer-2 Business VPN Services

- Deployment Use Case
 - Delivery of E-LINE services to business customers
- Benefits
 - Leverage same network for multiple services and customers (CAPEX)
Highly scalable
 - Service enablement only requires edge node configuration (OPEX)

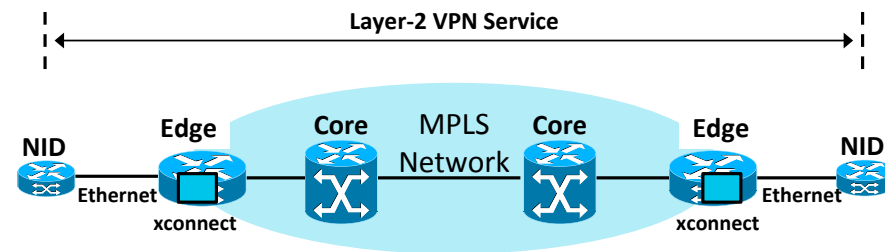

Network Segment	NID *	Edge	Core
MPLS Node	CE	U-PE	P
Typical Platforms	M3400 ASR901	ME3800X ASR903 ASR9K	CRS-1 GSR ASR9K

* NID : Network Interface Device

Data Center Deployment Scenario

VPLS for Layer-2 Data Center Interconnect (DCI) Services

- Deployment Use Case
 - E-LAN services for Data Center interconnect
- Benefits
 - Single WAN uplink to connect to multiple Data Centers
 - Easy implementation of segmented layer-2 traffic between Data Centers

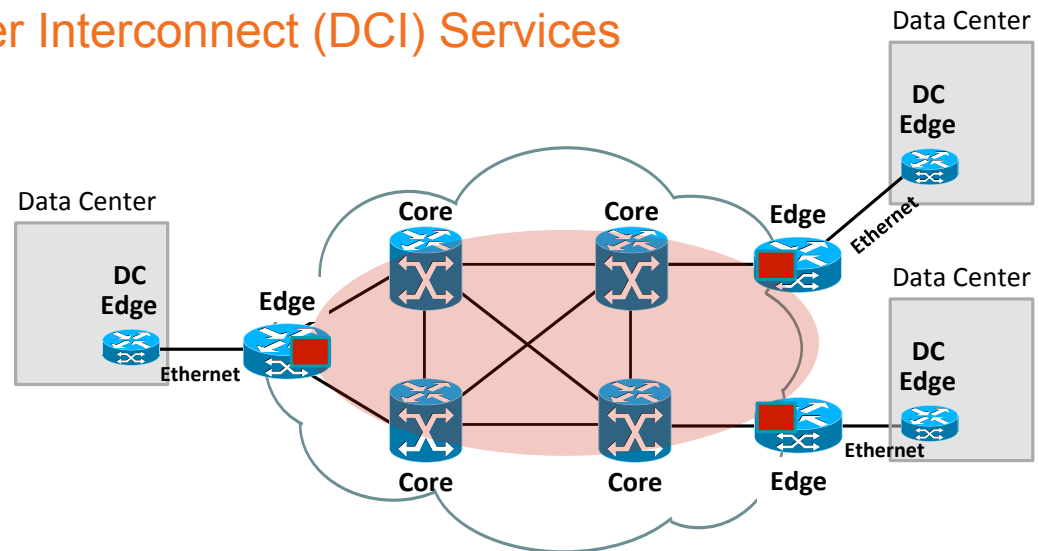

Network Segment	DC Edge	Core	Edge
MPLS Node	CE	P	PE
Typical Platforms	ASR9K 7600 6500	CRS-1 GSR ASR9K	ASR9K 7600

Summary

Key Takeaways

- L2VPNs enable transport of any Layer-2 traffic over MPLS network
- L2 packets encapsulated into additional VC label
- Both LDP and BGP can be used L2VPN signaling
- PWs suited for implementing transparent point-to-point connectivity between Layer-2 circuits (E-LINE services)
- VPLS suited for implementing transparent point-to-multipoint connectivity between Ethernet links/sites (E-LAN services)
- Typical applications of L2VPNs are layer-2 business VPN services and Data Center interconnect

Advanced Topics

Latest MPLS Technology Developments, Trends, and Futures

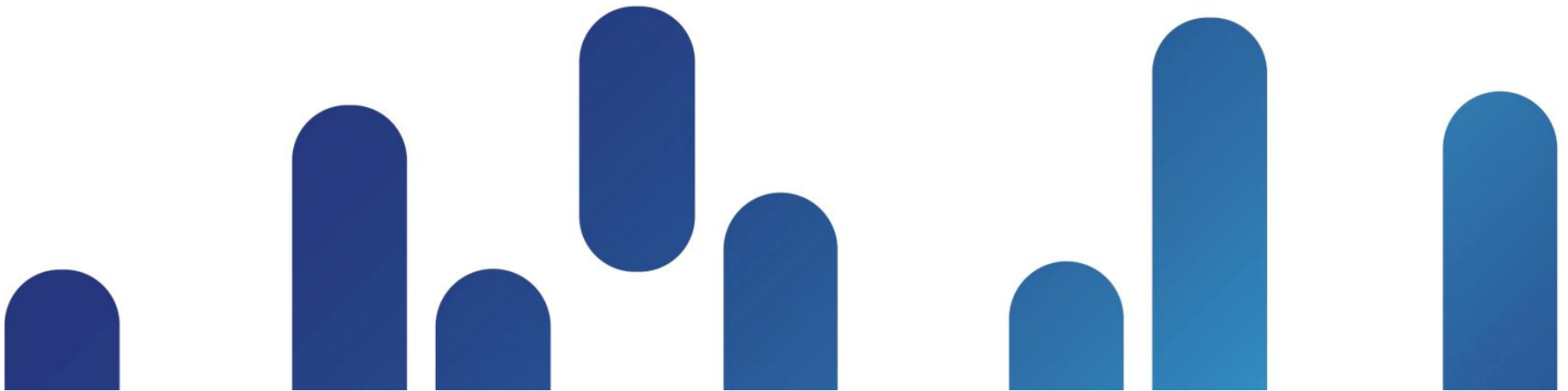

MPLS And IPv6

IPv6 Support for Native MPLS Deployments and MPLS Layer-3 Services

- IPv6 traffic carried over IPv4 MPLS network
- Encapsulation of IPv6 into IPv4 LSP (6PE)
- Encapsulation of IPv6 into MPLS layer-3 VPN (6VPE)
 - Translation of IPv6 to IPv4 at PE edge

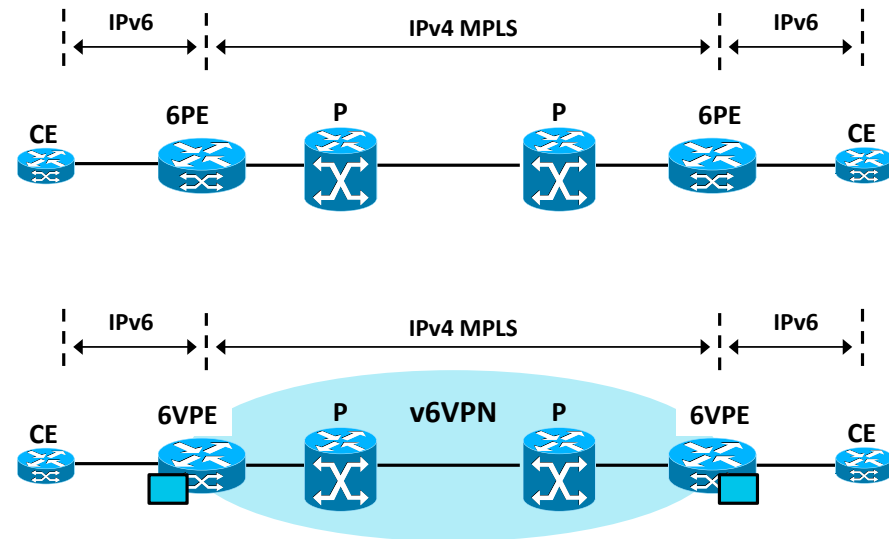

Label Switched Multicast (LSM)

Point-to-Multi-Point MPLS Signaling and Connectivity

- What is Label Switched Multicast?
 - MPLS extensions to provide P2MP connectivity
 - RSVP extensions and multicast LDP
- Why Label-Switched Multicast?
 - Enables MPLS capabilities, which can not be applied to IP multicast traffic (e.g., FRR)
- Benefits of Label-Switched Multicast
 - Efficient IP multicast traffic forwarding
 - Enables MPLS traffic protection and BW control of IP multicast traffic

MPLS / IP

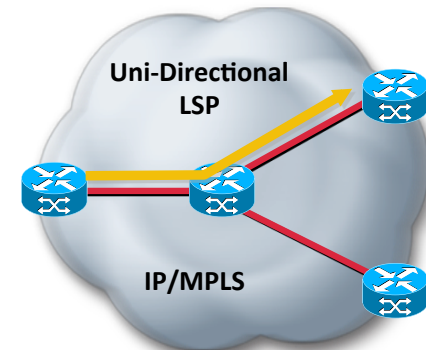

Label Switched Multicast (LSM)

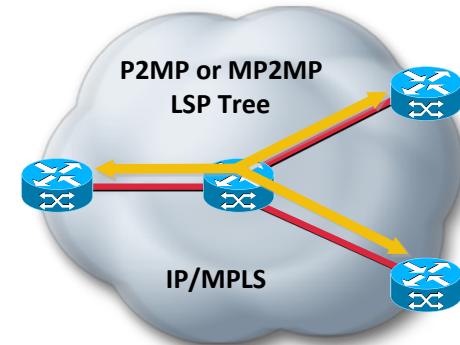

MPLS Transport Profile (TP)

Bi-Directional MPLS Tunnel Extensions For Transport Oriented Connectivity

- What is MPLS TP?
 - Point-to-point static LSPs which are co-routed
 - Bi-directional TP tunnel
- Why MPLS TP?
 - Migration of TDM legacy networks often assume continuation of connection-oriented operations model
 - MPLS TP enables packet-based transport with connection-oriented connectivity
- Benefits of MPLS TP
 - Meets transport-oriented operations requirements
 - Enables seamless migration to dynamic MPLS

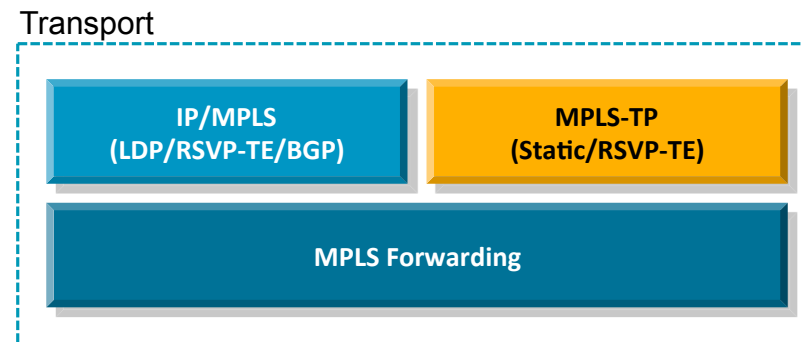
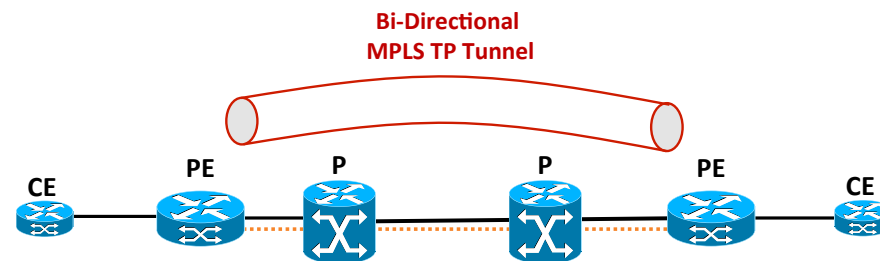

Futures

New MPLS Developments on the Horizon

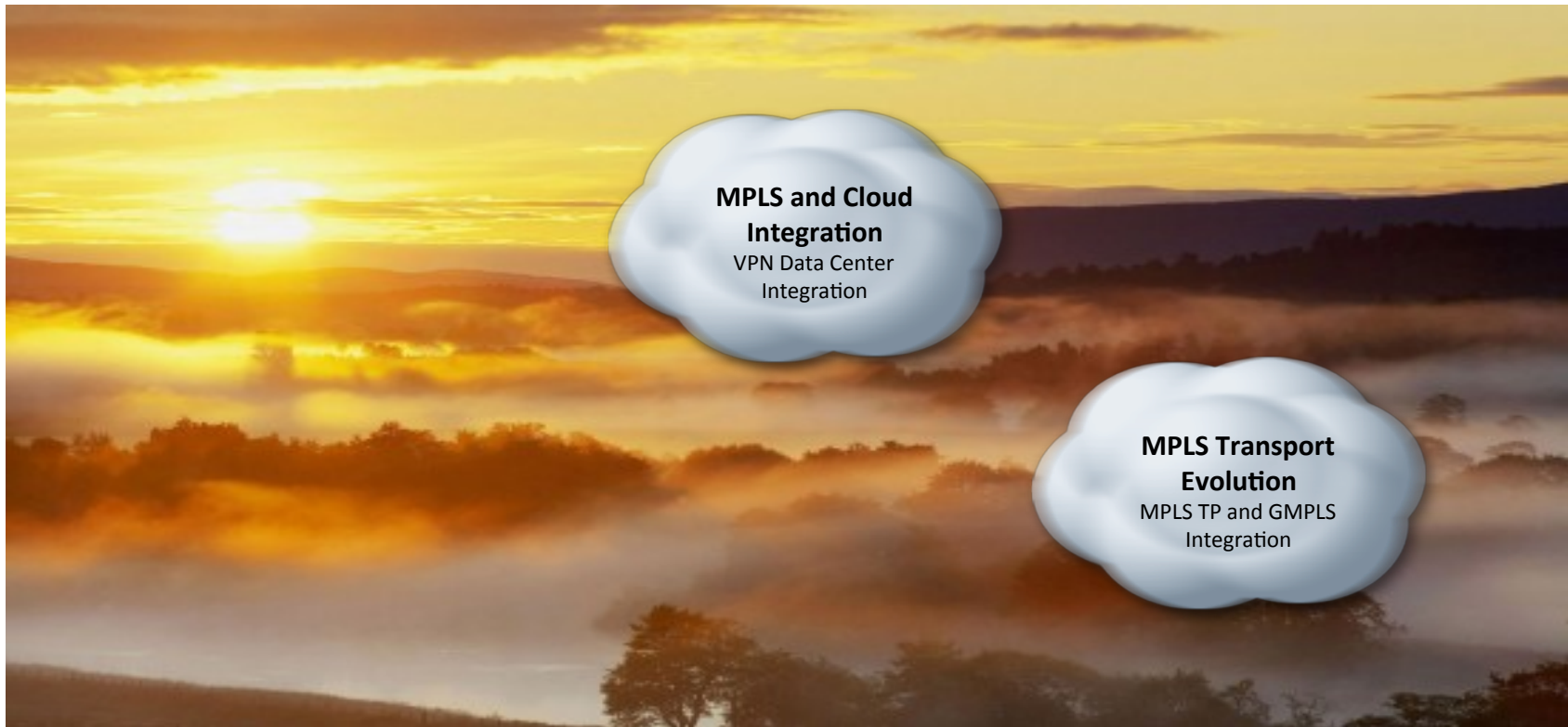

Summary

Final Notes and Wrap Up

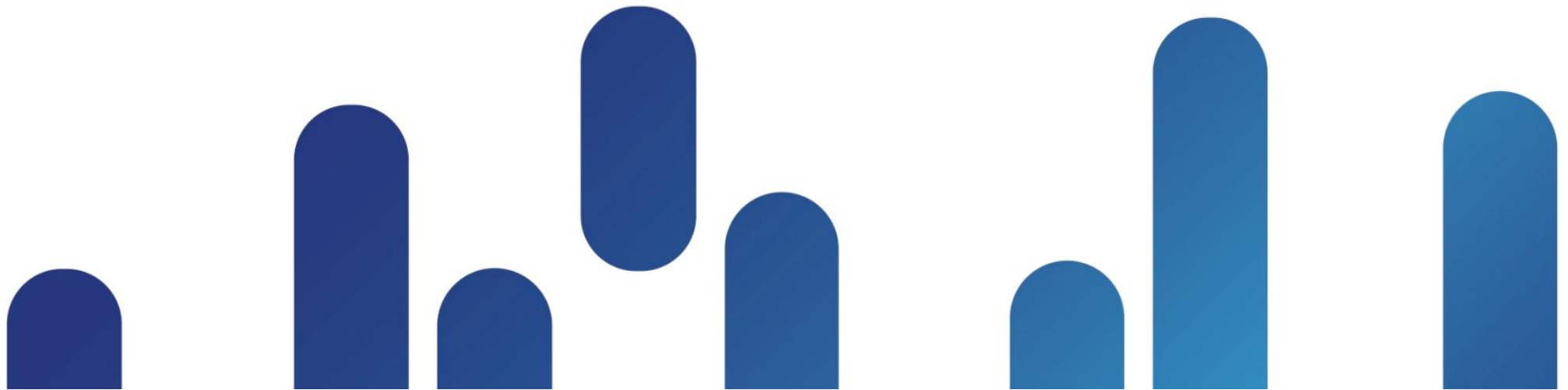



Summary

Key Takeaways

- It's all about labels ...
 - Label-based forwarding and protocol for label exchange
 - Best of both worlds ... L2 deterministic forwarding and scale/flexible L3 signaling
- Key MPLS applications are end-to-end VPN services
 - Secure and scalable layer 2 and 3 VPN connectivity
- MPLS supports advanced traffic engineering capabilities
 - QoS, bandwidth control, and failure protection
- MPLS is a mature technology with widespread deployments
 - Defacto for most SPs, large enterprises, and increasingly in Data Centers
- Ongoing technology evolution
 - IPv6, optimized video transport, TP transport evolution, and cloud integration

Consider MPLS When ...

Decision Criteria

- Is there a need for network segmentation?
 - Segmented connectivity for specific locations, users, applications, etc.
- Is there a need for flexible connectivity?
 - E.g., Flexible configuration of full-mesh or hub-and-spoke connectivity
- Is there a need for implementing/supporting multiple (integrated) services?
 - Leverage same network for multiple services
- Are there specific scale requirements?
 - Large number of users, customer routes, etc.
- Is there a need for optimized network availability and performance?
 - Node/link protection, pro-active connectivity validation
 - Bandwidth traffic engineering and QoS traffic prioritization

Terminology Reference

Acronyms Used in MPLS Reference Architecture

Terminology	Description
AC	Attachment Circuit. An AC Is a Point-to-Point, Layer 2 Circuit Between a CE and a PE.
AS	Autonomous System (a Domain)
CoS	Class of Service
ECMP	Equal Cost Multipath
IGP	Interior Gateway Protocol
LAN	Local Area Network
LDP	Label Distribution Protocol, RFC 3036.
LER	Label Edge Router. An Edge LSR Interconnects MPLS and non-MPLS Domains.
LFIB	Labeled Forwarding Information Base
LSP	Label Switched Path
LSR	Label Switching Router
NLRI	Network Layer Reachability Information
P Router	An Interior LSR in the Service Provider's Autonomous System
PE Router	An LER in the Service Provider Administrative Domain that Interconnects the Customer Network and the Backbone Network.
PSN Tunnel	Packet Switching Tunnel

Terminology Reference

Acronyms Used in MPLS Reference Architecture

Terminology	Description
Pseudo-Wire	A Pseudo-Wire Is a Bidirectional "Tunnel" Between Two Features on a Switching Path.
PWE3	Pseudo-Wire End-to-End Emulation
QoS	Quality of Service
RD	Route Distinguisher
RIB	Routing Information Base
RR	Route Reflector
RT	Route Target
RSVP-TE	Resource Reservation Protocol based Traffic Engineering
VPN	Virtual Private Network
VFI	Virtual Forwarding Instance
VLAN	Virtual Local Area Network
VPLS	Virtual Private LAN Service
VPWS	Virtual Private WAN Service
VRF	Virtual Route Forwarding Instance
VSI	Virtual Switching Instance



Further Reading

MPLS References at Cisco Press and cisco.com

- <http://www.cisco.com/go/mpls>
- <http://www.ciscopress.com>
- MPLS and VPN Architectures — Cisco Press®
 - Jim Guichard, Ivan Papelnjak
- Traffic Engineering with MPLS — Cisco Press®
 - Eric Osborne, Ajay Simha
- Layer 2 VPN Architectures — Cisco Press®
 - Wei Luo, Carlos Pignataro, Dmitry Bokotey, and Anthony Chan
- MPLS QoS — Cisco Press®
 - Santiago Alvarez

BUILT FOR
THE HUMAN
NETWORK

